

# XM-SD22X

## SERVICE MANUAL

Ver. 1.0 2004.12

US Model  
Canadian Model  
AEP Model  
UK Model  
E Model



### SPECIFICATIONS

#### AUDIO POWER SPECIFICATIONS (US MODEL)

POWER OUTPUT AND TOTAL HARMONIC DISTORTION  
200 watts per channel minimum continuous average power into  
4 ohms, both channels driven from 20 Hz to 20 kHz with no more  
than 0.1% total harmonic distortion per Car Audio Ad Hoc  
Committee standards.

#### Other Specifications

Circuit system	OTL (output transformerless) circuit Pulse power supply
Inputs	RCA pin jacks High level input connector
Outputs	Speaker terminals Through out pin jacks
Suitable speaker impedance	2 – 8 $\Omega$ (stereo) 4 – 8 $\Omega$ (when used as a bridging amplifier)
Maximum outputs	400 W $\times$ 2 (at 4 $\Omega$ ) 600 W $\times$ 2 (at 2 $\Omega$ ) 1,200 W (BTL, at 4 $\Omega$ )
Rated outputs (supply voltage at 14.4 V)	200 W RMS $\times$ 2 (20 Hz – 20 kHz, 0.1% THD + N, at 4 $\Omega$ ) 250 W RMS $\times$ 2 (20 Hz – 20 kHz, 0.15% THD + N, at 2 $\Omega$ ) 500 W RMS (BTL) (20 Hz – 20 kHz, 0.15% THD + N, at 4 $\Omega$ )
SN Ratio	93 dBA (Reference 1W into 4 $\Omega$ )
Frequency response	5 Hz – 50 kHz ( $\pm 3$ dB)

Input level adjustment range	0.3 – 6.0 V (RCA pin jacks) 1.2 – 12.0 V (High level input)
Low-pass filter	50 – 300 Hz, –12 dB/oct
Low boost	0 – 10 dB (40 Hz)
Power requirements	12 V DC car battery (negative ground)
Power supply voltage	10.5 – 16 V
Current drain	at rated output : 48 A (at 4 $\Omega$ ) Remote input : 1 mA
Dimensions	Approx. 403 $\times$ 55 $\times$ 277 mm (15 $\frac{7}{8}$ $\times$ 2 $\frac{1}{4}$ $\times$ 11 in.) (w/h/d) not incl. projecting parts and controls
Mass	Approx. 5 kg (11 lb. 1 oz.) not incl. accessories
Supplied accessories	Mounting screws (4) High level input cord (1) Protection cap (1)

*Design and specifications are subject to change without notice.*

## STEREO POWER AMPLIFIER

9-879-367-01  
2004L04-1  
© 2004.12

**Sony Corporation**  
e Vehicle Company  
Published by Sony Engineering Corporation

# SONY®

**Note for Replacement of FET**

Change the both channels of FETs at the output stage.  
If one or both parts in the following combination is broken, the service kit should be ordered.

	Service kit part No.
Q108, 110, 112	X-3383-027-1
Q208, 210, 212	
Q109, 111, 113	X-3383-028-1
Q209, 211, 213	

**TABLE OF CONTENTS**

**1. GENERAL**  
 Location and Function of Controls ..... 3  
 Connections ..... 4

**2. DISASSEMBLY**  
 2-1. Bottom Plate ..... 7  
 2-2. Main Board Section ..... 8  
 2-3. Main Board ..... 8  
 2-4. LED Board ..... 9

**3. ELECTRICAL ADJUSTMENT** ..... 10

**4. DIAGRAMS**  
 4-1. Block Diagram ..... 11  
 4-2. Schematic Diagram –Main Section (1/2)– ..... 12  
 4-3. Schematic Diagram –Main Section (2/2)– ..... 13  
 4-4. Printed Wiring Boards –Main Section– ..... 14

**5. EXPLODED VIEWS**  
 5-1. Heat Sink (Main) Section ..... 16  
 5-2. Main Board Section ..... 17

**6. ELECTRICAL PARTS LIST** ..... 18

**Notes on Chip Component Replacement**

- Never reuse a disconnected chip component.
- Notice that the minus side of a tantalum capacitor may be damaged by heat.

**SAFETY-RELATED COMPONENT WARNING!!**

COMPONENTS IDENTIFIED BY MARK  $\triangle$  OR DOTTED LINE WITH MARK  $\triangle$  ON THE SCHEMATIC DIAGRAMS AND IN THE PARTS LIST ARE CRITICAL TO SAFE OPERATION. REPLACE THESE COMPONENTS WITH SONY PARTS WHOSE PART NUMBERS APPEAR AS SHOWN IN THIS MANUAL OR IN SUPPLEMENTS PUBLISHED BY SONY.

**ATTENTION AU COMPOSANT AYANT RAPPORT À LA SÉCURITÉ!!**

LES COMPOSANTS IDENTIFIÉS PAR UNE MARQUE  $\triangle$  SUR LES DIAGRAMMES SCHÉMATIQUES ET LA LISTE DES PIÈCES SONT CRITIQUES POUR LA SÉCURITÉ DE FONCTIONNEMENT. NE REMPLACER CES COMPOSANTS QUE PAR DES PIÈCES SONY DONT LES NUMÉROS SONT DONNÉS DANS CE MANUEL OU DANS LES SUPPLÉMENTS PUBLIÉS PAR SONY.

# SECTION 1 GENERAL

This section is extracted from instruction manual.

## Low boost Amplification de basses fréquences

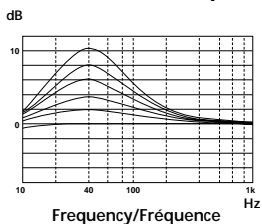

## Cut-off frequency (LPF) Fréquence de coupure (LPF)

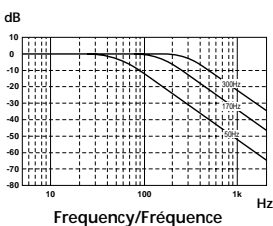

## Circuit Diagram Schéma du circuit

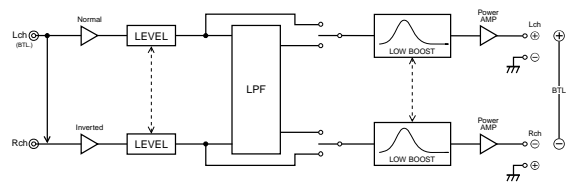

## Features

- Maximum power output of 400W per channel (at 4 Ω).
- This unit can be used as a bridging amplifier with a maximum output of 1,200 W.
- Direct connection can be made with the speaker output of your car audio unit if it is not equipped with a line output (High level input connection).
- Built-in variable LPF (Low-pass filter) and low boost circuit.
- Dual mode connection possible for a multi-speaker system.
- Protection circuit.
- Pulse power supply\* for stable, regulated output power.

### \* Pulse power supply

This unit has a built-in power regulator which converts the power supplied by the DC 12 V car battery into high speed pulses using a semiconductor switch. These pulses are stepped up by the built-in pulse transformer and separated into both positive and negative power supplies before being converted into direct current again. This light weight power supply system provides a highly efficient power supply with a low impedance output.

## Caractéristiques

- Puissance de sortie maximale de 400W par canal (à 4 Ω).
- Cet appareil peut être utilisé comme amplificateur en pont d'une sortie maximale de 1,200W.
- Une connexion directe est possible avec la sortie haut-parleur de votre autoradio si celle-ci n'est pas équipée d'une sortie de ligne (connexion d'entrée haut niveau).
- Filtre passe-bas (LPF) intégré et circuit d'amplification de basses fréquences.
- Double mode de connexion possible au moyen d'un système à plusieurs haut-parleurs.
- Circuit de protection.
- Alimentation électrique par impulsions\* pour une puissance de sortie stable, régulée.

### \* Alimentation électrique par impulsions

Cet appareil est équipé d'un régulateur de puissance intégré qui convertit la puissance fournie par une batterie de voiture de 12 V CC en impulsions ultra-rapides au moyen d'un commutateur à semi-conducteur. Ces impulsions sont amplifiées par le transformateur d'impulsions intégré et séparées en alimentation positive et négative avant d'être reconverties en courant continu. Ce système d'alimentation de faible poids assure une alimentation électrique très efficace pour une sortie d'impédance faible.

## Location and Function of Controls

- 1 PROTECTOR indicator**  
When the PROTECTOR is activated, the indicator lights up in red.  
When the PROTECTOR is activated refer to the Troubleshooting Guide.
- 2 LEVEL adjustment control**  
The input level can be adjusted with this control. Turn it in the clockwise direction when the output level of the car audio unit seems low.
- 3 LOW BOOST level control**  
Turn this control to boost the frequencies around 40 Hz to a maximum of 10 dB.
- 4 Cut-off frequency adjustment control**  
Sets the cut-off frequency (50 – 300 Hz) for the low-pass filter.
- 5 FILTER selector switch**  
When the switch is in the LPF position, the filter is set to low-pass.

## Emplacement et fonction des commandes

- 1 Indicateur PROTECTOR**  
Lorsque PROTECTOR est activé, l'indicateur s'allume en rouge.  
Lorsque PROTECTOR est activé, reportez-vous au guide de dépannage.
- 2 Commande de réglage LEVEL**  
Le niveau d'entrée peut se régler avec cette commande. Tournez cette commande dans le sens des aiguilles d'une montre lorsque le niveau de sortie de l'autoradio semble faible.
- 3 Commande de niveau LOW BOOST**  
Tournez cette commande pour amplifier les fréquences autour de 40 Hz jusqu'à un maximum de 10 dB.
- 4 Commandes de réglage de la fréquence de coupure**  
Permet de régler la fréquence de coupure (50 – 300 Hz) pour le filtre passe-bas.
- 5 Sélecteur FILTER**  
Lorsque le sélecteur est en position LPF, le filtre est réglé sur passe-bas.

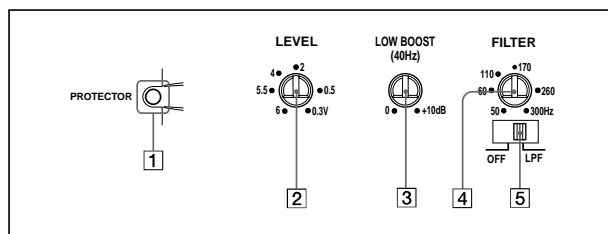

# Connections

## Caution

- Before making any connections, disconnect the ground terminal of the car battery to avoid short circuits.
- Be sure to use speakers with an adequate power rating. If you use small capacity speakers, they may be damaged.
- Do not connect the ⊖ terminal of the speaker system to the car chassis, and do not connect the ⊖ terminal of the right speaker with that of the left speaker.
- Install the input and output cords away from the power supply wire as running them close together can generate some interference noise.
- This unit is a high powered amplifier.
- Therefore, it may not perform to its full potential if used with the speaker cords supplied with the car.
- If your car is equipped with a computer system for navigation or some other purpose, do not remove the ground wire from the car battery. If you disconnect the wire, the computer memory may be erased. To avoid short circuits when making connections, disconnect the +12 V power supply wire until all the other wires have been connected.

# Connexions

## Attention

- Avant d'effectuer les connexions, débranchez la borne de masse de la batterie de voiture pour éviter tout court-circuit.
- Veillez à utiliser des haut-parleurs de puissance adéquate. Si vous utilisez des haut-parleurs de faible capacité, ils risquent d'être endommagés.
- Ne raccordez pas la borne ⊖ du système de haut-parleurs à la carrosserie de la voiture ni la borne ⊖ du haut-parleur droit avec celle du haut-parleur gauche.
- Éloignez les câbles d'entrée et de sortie du câble d'alimentation pour éviter les interférences.
- Cet appareil est un amplificateur de haute puissance. Il ne peut donc déployer sa pleine puissance que si les câbles de haut-parleurs de la voiture lui sont raccordés.
- Si votre voiture est équipée d'un système de navigation ou d'un ordinateur de bord, ne retirez pas le fil de terre de la batterie de la voiture, sinon les données mémorisées seront effacées. Pour éviter un court-circuit lorsque vous effectuez les branchements, branchez le câble d'alimentation +12 V après avoir branché tous les autres fils.

Make the terminal connections as illustrated below.  
Procédez aux connexions des bornes comme illustré ci-dessous.

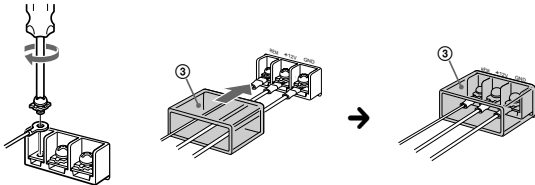

Pass the wires through the cap, connect the wires, then cover the terminals with the cap.

**Note**  
When you tighten the screw, be careful not to apply too much torque as doing so may damage the screw.  
\* The torque value should be less than 1 N.m.

Faites passer les fils par le cache, raccordez les fils, puis recouvrez les bornes avec le cache.

**Remarque**  
Lorsque vous vissez la vis, faites attention à ne pas appliquer une trop grande force\*, car cela pourrait l'endommager.  
\* Le couple de torsion doit être inférieur à 1 N.m.

## Power Connection Wires Câbles d'alimentation

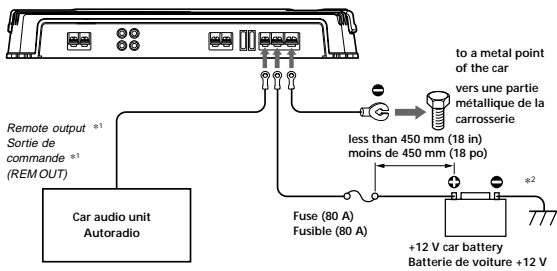

<sup>s1</sup> If you have the factory original or some other car audio unit without a remote output for the amplifier, connect the remote input terminal (REMOTE) to the accessory power supply.  
<sup>s1</sup> Si vous disposez du modèle d'origine ou d'un autre autoradio sans aucune sortie de commande à distance pour l'amplificateur, raccordez la borne d'entrée de la commande à distance (REMOTE) à la prise d'alimentation accessoires.

### Notes on the power supply

- Connect the +12 V power supply wire only after all the other wires have been connected.
- Be sure to connect the ground wire of the unit securely to a metal point of the car. A loose connection may cause a malfunction of the amplifier.
- Be sure to connect the remote control wire of the car audio unit to the remote terminal.
- When using a car audio unit without a remote output on the amplifier, connect the remote input terminal (REMOTE) to the accessory power supply.
- Use the power supply wire with a fuse attached (80 A).
- All power wires connected to the positive battery post should be fused within 450 mm (18 in) of the battery post, and before they pass through any metal.
- Make sure that the vehicle's battery wires connected to the vehicle (ground to chassis)<sup>s2</sup> are of a wire gauge at least equal to that of the main power wire connected from the battery to the amplifier.
- Make sure that the wires to be connected to the +12 V and GND terminals of this unit are at least 4-Gauge (AWG-4) or have a sectional area of more than 22.0 mm<sup>2</sup> (7/8 in<sup>2</sup>).

### Remarque sur l'alimentation électrique

- Raccordez le câble d'alimentation +12 V uniquement après avoir réalisé toutes les autres connexions.
- Raccordez correctement le fil de masse à une partie métallique de la voiture. Une connexion lâche peut provoquer un dysfonctionnement de l'amplificateur.
- Veillez à raccorder le fil de commande à distance de l'autoradio à la borne de commande à distance.
- Si vous utilisez un autoradio dont l'amplificateur ne comporte pas de sortie de commande à distance, raccordez la borne d'entrée de la commande à distance (REMOTE) à la prise d'alimentation accessoires.
- Utilisez un câble d'alimentation muni d'un fusible (80 A).
- Tous les fils électriques raccordés au support de batterie positif doivent être protégés par un fusible à une distance maximum de 450 mm (18 po) du support de batterie et avant de passer dans une partie métallique quelconque.
- Assurez-vous que les fils de la batterie du véhicule raccordés à ce dernier (sol au châssis)<sup>s2</sup> sont d'un calibre au moins égal à celui du fil électrique principal reliant la batterie et l'amplificateur.
- Assurez-vous que les câbles à raccorder aux bornes +12V et GND de cet appareil sont d'un calibre d'au moins 4 (AWG-4) ou d'une section supérieure à 22,0 mm<sup>2</sup> (7/8 po<sup>2</sup>).

## 2-Speaker System Système à 2 haut-parleurs

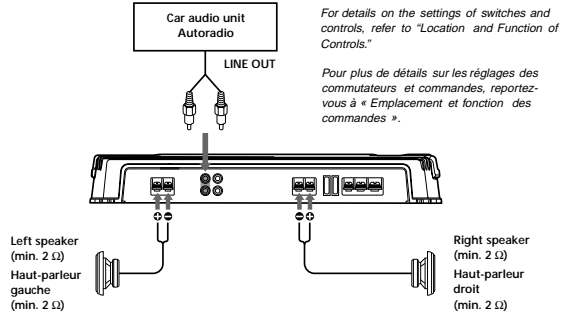

For details on the settings of switches and controls, refer to "Location and Function of Controls."

Pour plus de détails sur les réglages des commutateurs et commandes, reportez-vous à « Emplacement et fonction des commandes ».

## As a Monaural Amplifier Comme amplificateur monaural

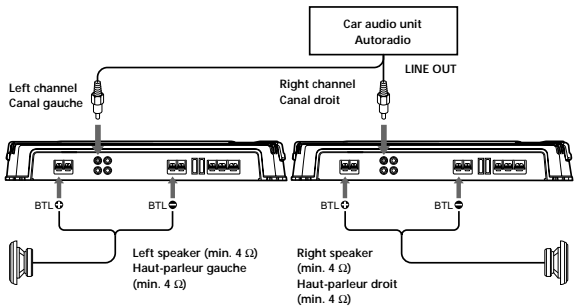

For details on the settings of switches and controls, refer to "Location and Function of Controls."

**Note**  
Make sure that the line output from the car audio unit is connected to the jack marked "L (BTL)" on the unit.

Pour plus de détails sur les réglages des commutateurs et commandes, reportez-vous à « Emplacement et fonction des commandes ».

**Remarque**  
Vérifiez que la sortie de ligne de l'autoradio est raccordée à la prise portant l'indication « L (BTL) » sur l'appareil.

## As the Monaural Amplifier for a Subwoofer Comme amplificateur monaural pour un haut-parleur d'extrêmes graves

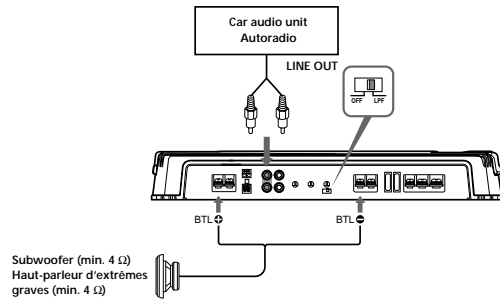

For details on the settings of switches and controls, refer to "Location and Function of Controls."

**Note**  
If you wish to use a subwoofer as a monaural speaker, connect the speaker as illustrated above. The output signals to the subwoofer will be the combination of the both right and left output signals.

Pour plus de détails sur les réglages des commutateurs et commandes, reportez-vous à « Emplacement et fonction des commandes ».

**Remarque**  
Si vous désirez utiliser un haut-parleur d'extrêmes graves comme haut-parleur monaural, raccordez le haut-parleur comme illustré ci-dessus. Les signaux de sortie vers le haut-parleur d'extrêmes graves seront une combinaison des signaux de sortie droit et gauche.

### 2-way System Système 2 voies

Two output channels  
Deux canaux de sortie

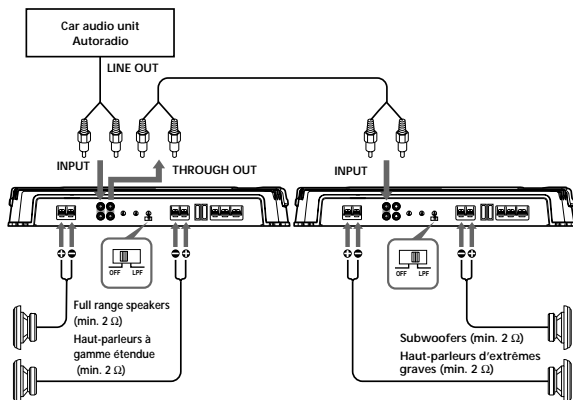

When you connect amplifiers using the THROUGH OUT pin jacks, it allows you to connect up to a maximum of three. Otherwise the necessary output levels can not be obtained, and your car audio unit may be damaged.

Use the THROUGHOUT terminal when you install more amplifiers. Audio signals pass through the THROUGHOUT pin jacks unaffected by any signal processing.

Lorsque vous raccordez des amplificateurs à l'aide des prises à broches THROUGHOUT, vous pouvez raccorder jusqu'à trois amplificateurs. Sinon les niveaux de sortie requis ne peuvent pas être obtenus et votre auto-radio risque d'être endommagé.

Utilisez la borne THROUGHOUT lorsque vous installez plusieurs amplificateurs. Les signaux audio transitent par les prises à broches THROUGHOUT sans subir aucun traitement.

### Four output channels Quatre canaux de sortie

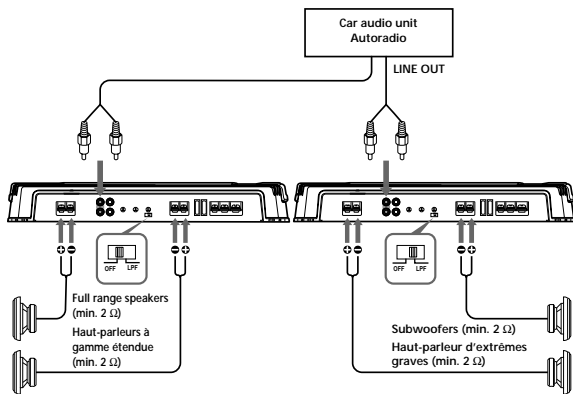

For details on the settings of switches and controls, refer to "Location and Function of Controls."

**Note**  
In this system, the volume of the subwoofers will be controlled by the car audio unit fader control.

Pour plus de détails sur les réglages des commutateurs et commandes, reportez-vous à « Emplacement et fonction des commandes ».

**Remarque**  
Dans ce système, le volume des haut-parleurs d'extrêmes graves est contrôlé par la commande de balance avant/arrière de l'autoradio.

### Dual Mode System (With a Bridged Subwoofer) Double mode de connexion (avec un haut-parleur d'extrêmes graves en pont)

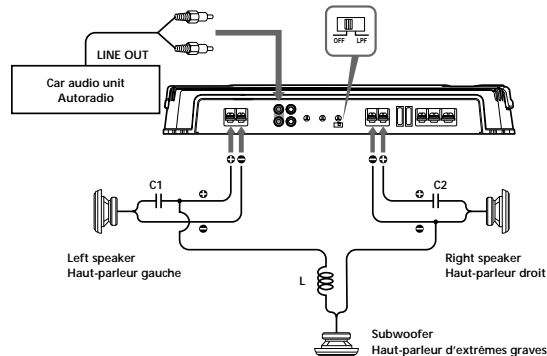

Table of crossover values for 6 dB/octave (4 Ω)

Crossover Frequency unit: Hz	L (coil)* unit: mH	C1/C2 (capacitor)* unit: μF
50	12.7	800
80	8.2	500
100	6.2	400
130	4.7	300
150	4.2	270
200	3.3	200
260	2.4	150
400	1.6	100
600	1.0	68
800	0.8	50
1000	0.6	39

\* (not supplied)

Tableau des valeurs de recoupelement pour 6 dB/octave (4 Ω)

Fréquence de recoupelement unité : Hz	L (bobine)* unité : mH	C1/C2 (condensateur)* unité : μF
50	12,7	800
80	8,2	500
100	6,2	400
130	4,7	300
150	4,2	270
200	3,3	200
260	2,4	150
400	1,6	100
600	1,0	68
800	0,8	50
1000	0,6	39

\* (non fournis)

**Notes**

- When using passive crossover networks in a multi-speaker system, care must be taken as the speaker system's impedance should not be lower than that of the suitable impedance for this unit.
- When you are installing a 12 decibels/octave system in your car, the following points must be considered. In a 12 decibels/octave system where both a choke and capacitor are used in series to form a circuit, a great care must be taken when they are connected. In such a circuit, there is going to be an increase in the current which bypasses the speaker with frequencies at around the crossover frequency. If audio signals are continued to be fed into the crossover frequency area, it may cause the amplifier to become abnormally hot or the fuse will be blown. Also if the speaker is disconnected, a series-resonant circuit will be formed by the choke and the capacitor. In this case, the impedance in the resonance area will decrease dramatically resulting in a short circuit like situation causing a damage to the amplifier. Therefore, make sure that a speaker is connected to such a circuit at all times.

**Remarques**

- Lorsque vous utilisez des circuits de recoupelement de fréquence passifs dans un système à plusieurs haut-parleurs, assurez-vous que l'impédance du système n'est pas inférieure à celle prévue pour cet appareil.
- Lorsque vous installez un système à 12 décibels/octave dans votre voiture, vous devez respecter les points suivants. Dans un système à 12 décibels/octave où la bobine d'arrêt et le condensateur sont utilisés en série pour former un circuit, vous devez réaliser les branchements avec beaucoup de précaution. Dans ce type de circuit, une augmentation du courant contournant le haut-parleur se produit dans les fréquences se situant autour de la fréquence de coupure. Si des signaux audio continuent d'être fournis dans la zone de la fréquence de recoupelement, une surchauffe risque de se produire dans l'amplificateur et le fusible risque de griller. Si le haut-parleur n'est pas raccordé, un circuit de résonance série sera créé par la bobine et le condensateur. Dans ce cas, l'impédance dans la zone de résonance sera considérablement réduite, et comme dans le cas d'un court-circuit, l'amplificateur peut être endommagé. Par conséquent, veillez à ce qu'un haut-parleur soit toujours raccordé au circuit.

### High Level Input Connection (As a Monaural Amplifier for a Subwoofer) Connexion d'entrée à haut niveau (Comme amplificateur monaural pour un haut-parleur d'extrêmes graves)

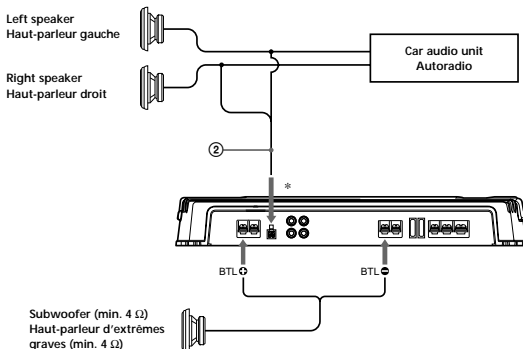

For details on the settings of switches and controls, refer to "Location and Function of Controls."

**Note**  
If you wish to use a subwoofer as a monaural speaker, connect the speaker as illustrated above. The output signals to the subwoofer will be the combination of both right and left output signals.

Pour plus de détails sur les réglages des commutateurs et commandes, reportez-vous à « Emplacement et fonction des commandes ».

**Remarque**  
Si vous désirez utiliser un haut-parleur d'extrêmes graves comme haut-parleur monaural, raccordez le haut-parleur comme illustré ci-dessus. Les signaux de sortie vers le haut-parleur d'extrêmes graves seront une combinaison des signaux de sortie droit et gauche.

**High Level Input Connection (2-Speaker System)**  
**Connexion d'entrée à haut niveau**  
 (Système à 2 haut-parleurs)

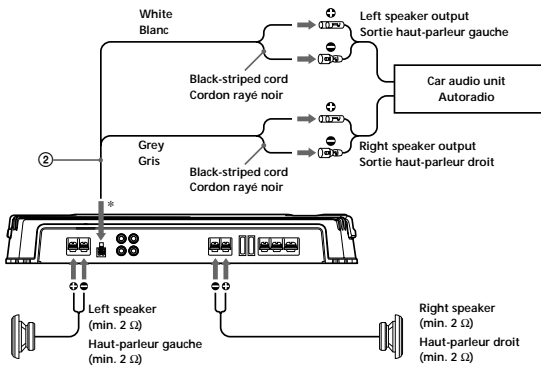

For details on the settings of switches and controls, refer to "Location and Function of Controls."

Pour plus de détails sur les réglages des commutateurs et commandes, reportez-vous à « Emplacement et fonction des commandes ».

**High Level Input Connection (As a Monaural Amplifier)**  
**Connexion d'entrée à haut niveau**  
 (Comme amplificateur monaural)

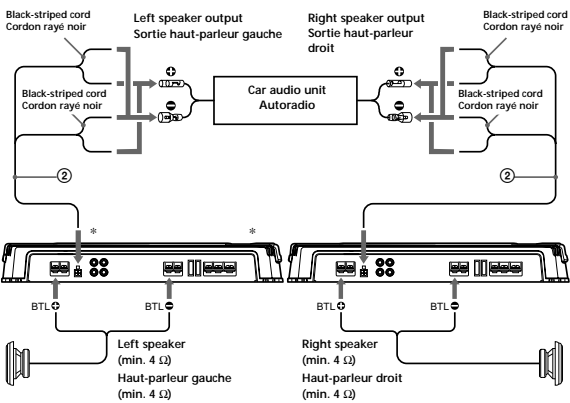

For details on the settings of switches and controls, refer to "Location and Function of Controls."

Pour plus de détails sur les réglages des commutateurs et commandes, reportez-vous à « Emplacement et fonction des commandes ».

**\* High Level Input Connector**

**\* Connecteur d'entrée à haut niveau**

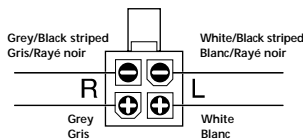

## SECTION 2 DISASSEMBLY

**Note :** This set can be disassemble according to the following sequence.

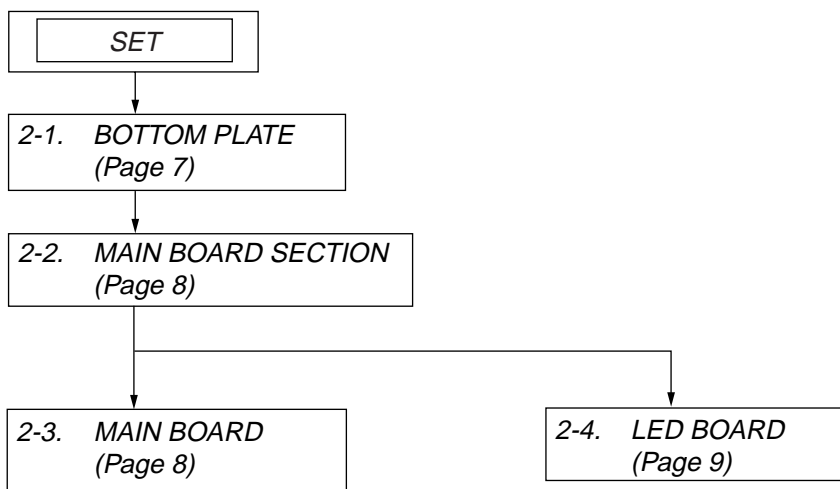

**Note :** Follow the disassembly procedure in the numerical order given.

### 2-1. BOTTOM PLATE

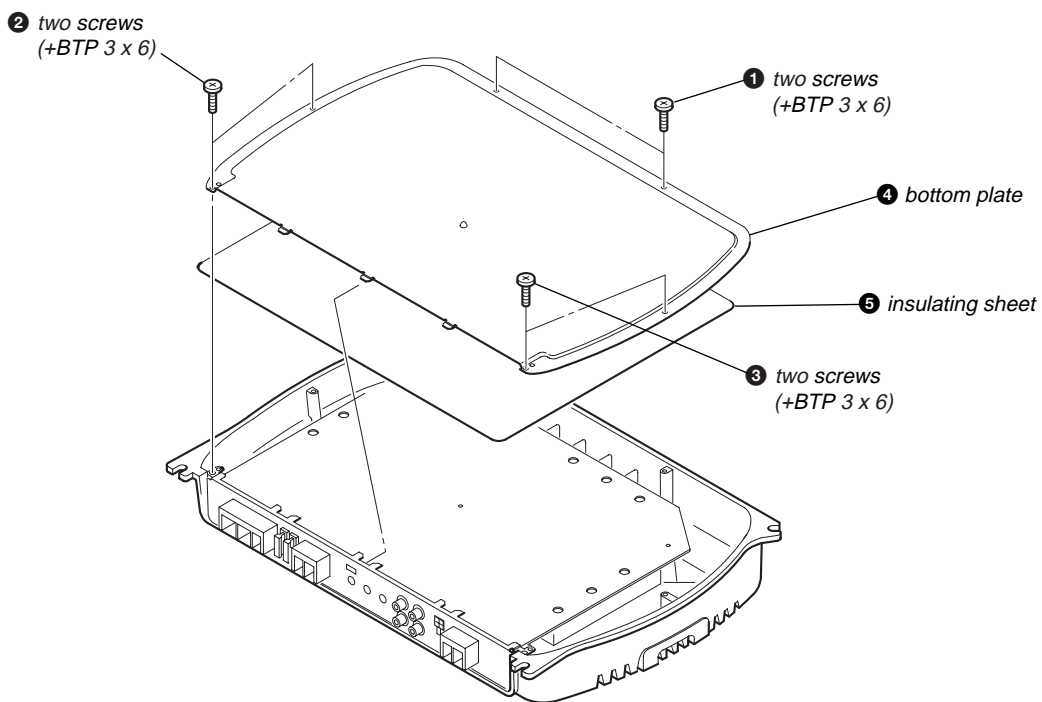

**2-2. MAIN BOARD SECTION**

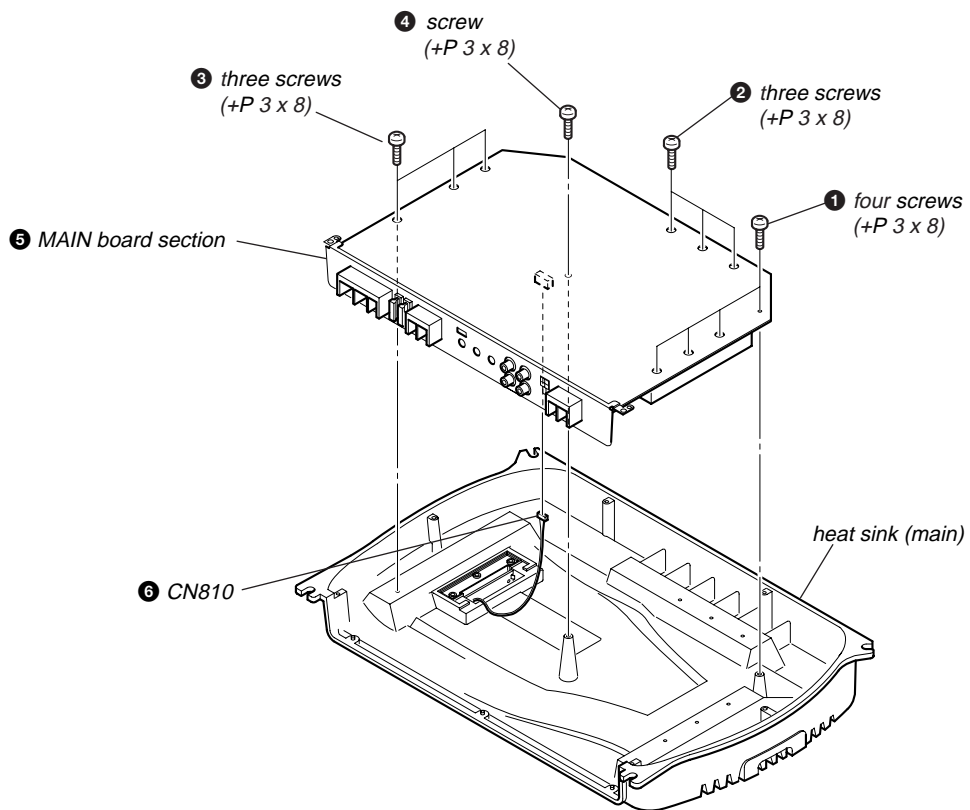

**2-3. MAIN BOARD**

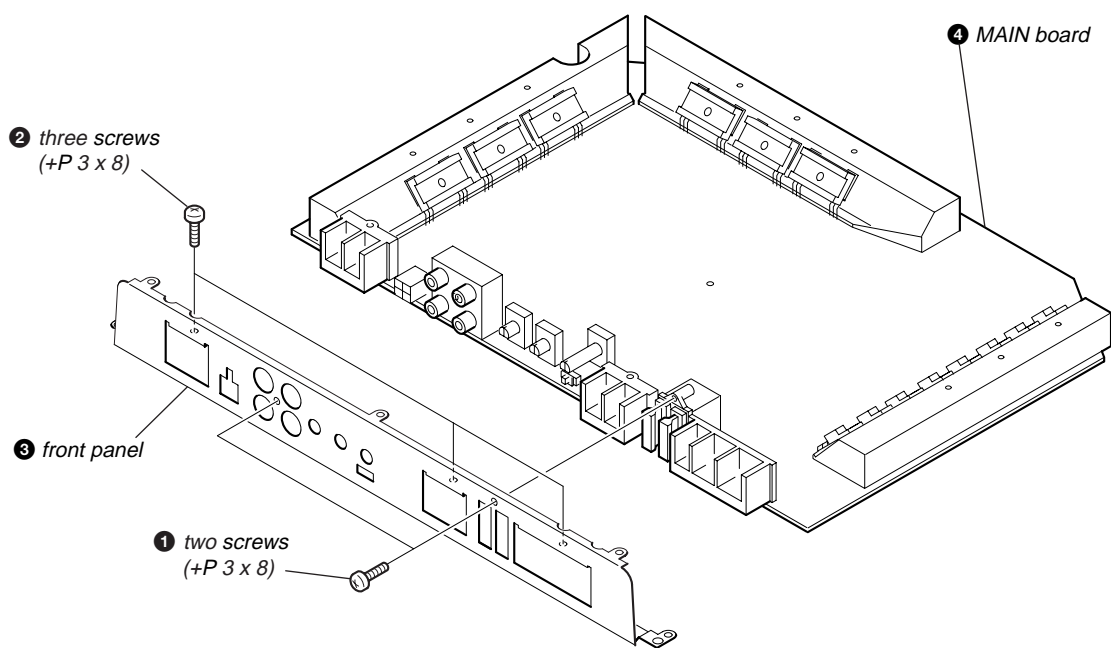



**2-4. LED BOARD**

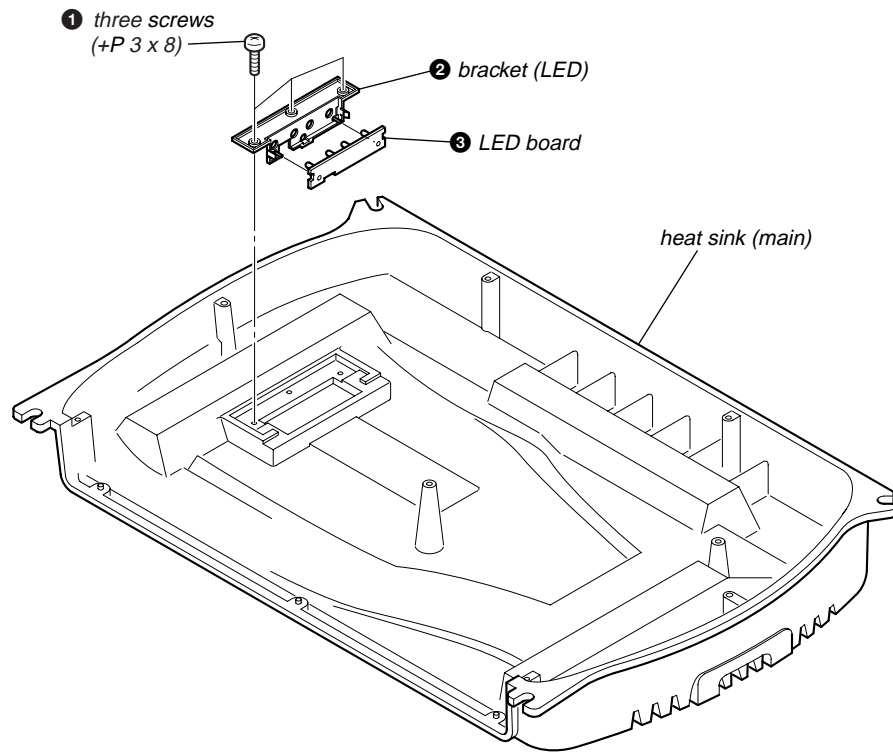

**SECTION 3  
ELECTRICAL ADJUSTMENT**

**Bias Adjustment**

**Note :** In Bias Adjustment, adjust RV103 if any of Q108 through Q113 are replaced. Adjust RV203 if any of Q208 through Q213 are replaced.

**Condition :** This adjustment should be performed about one minute after the remote mode is turned on at a room temperature of about 25°C.

**Setting :**

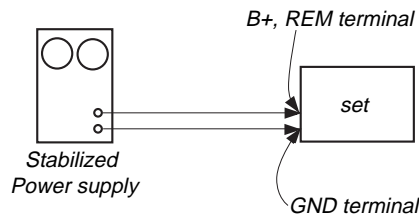

**Procedure :**

1. Turn the variable resistors RV103 (L-CH) and RV203 (R-CH) full clockwise as seen from the component side to minimize the bias current.
2. The input signal is to be no signal.
3. Apply the voltage to the B+ and REM terminals from the stabilized power supply and gradually increase it up to 12.0 V while checking for any unusual current.
4. Adjust each of RV103 (L-CH) and RV203 (R-CH) so that the power current of the stabilized power supply is increased in steps of 700 mA (total of 1.4 A).
5. After adjustment, check that the power current is at 1.65 to 2.05 A.

**Adjustment Location :** Main board (component side)

— MAIN BOARD (CONDUCTOR SIDE) —

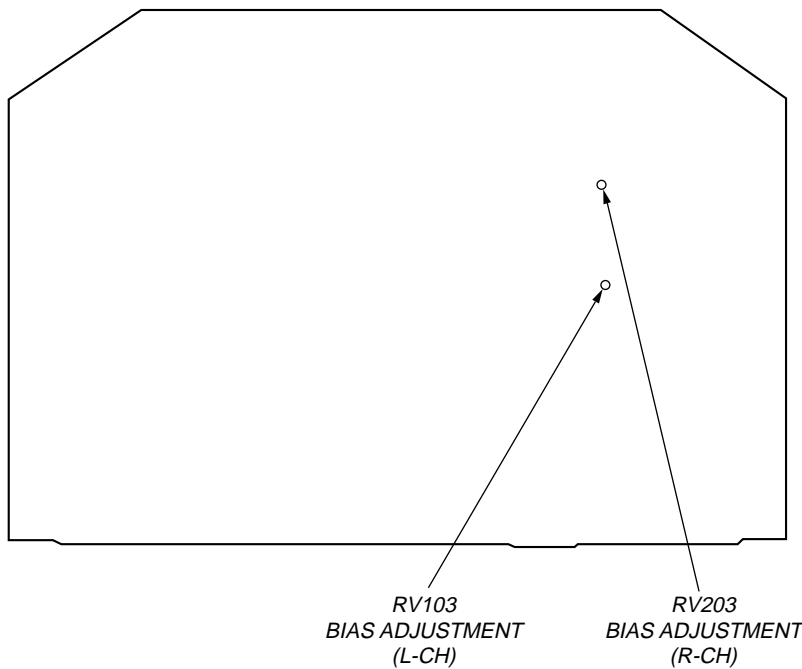

### SECTION 4 DIAGRAMS

#### 4-1. BLOCK DIAGRAM

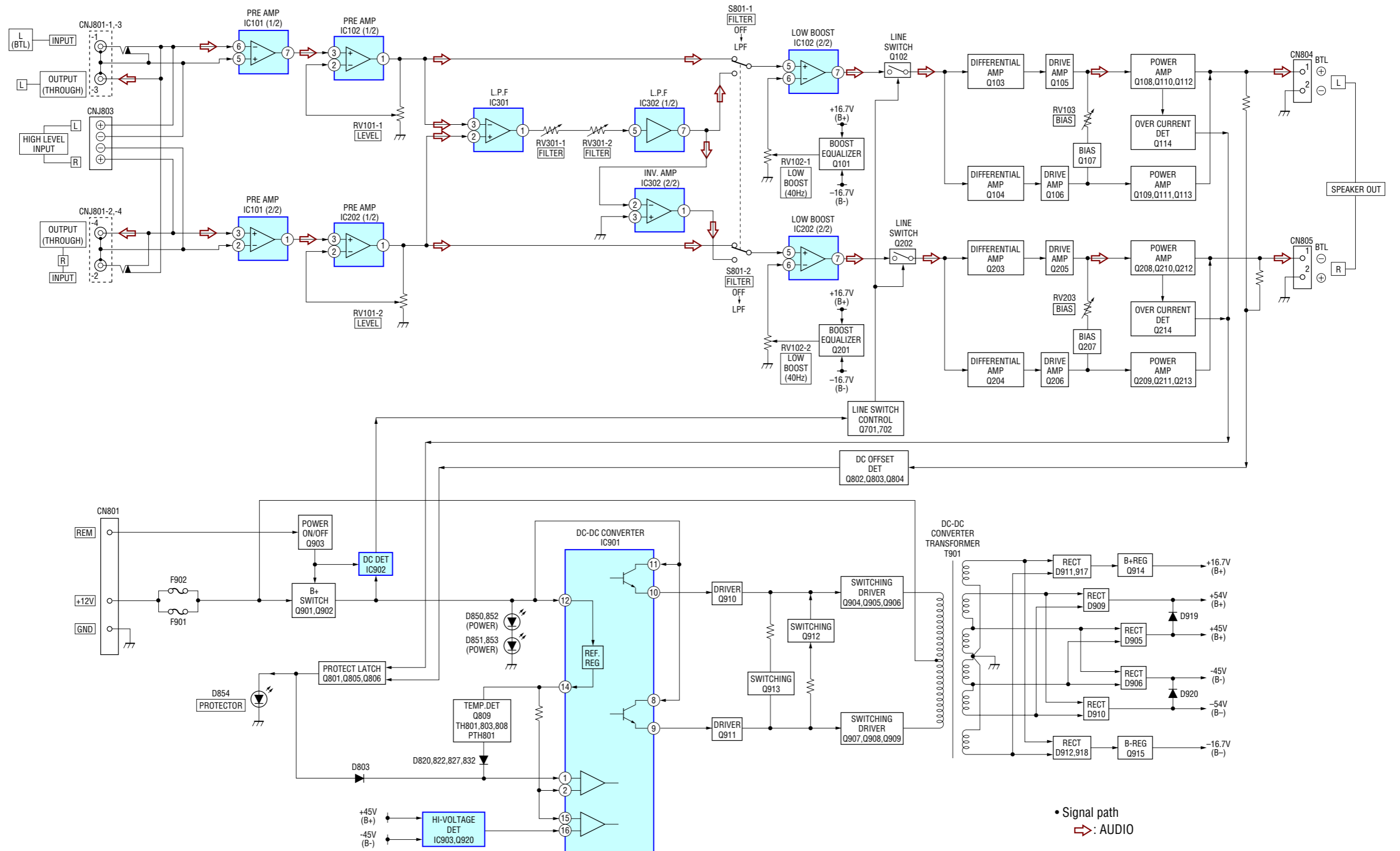

4-2. SCHEMATIC DIAGRAM — MAIN SECTION (1/2) — • Refer to page 15 for Waveform and IC Block Diagram.

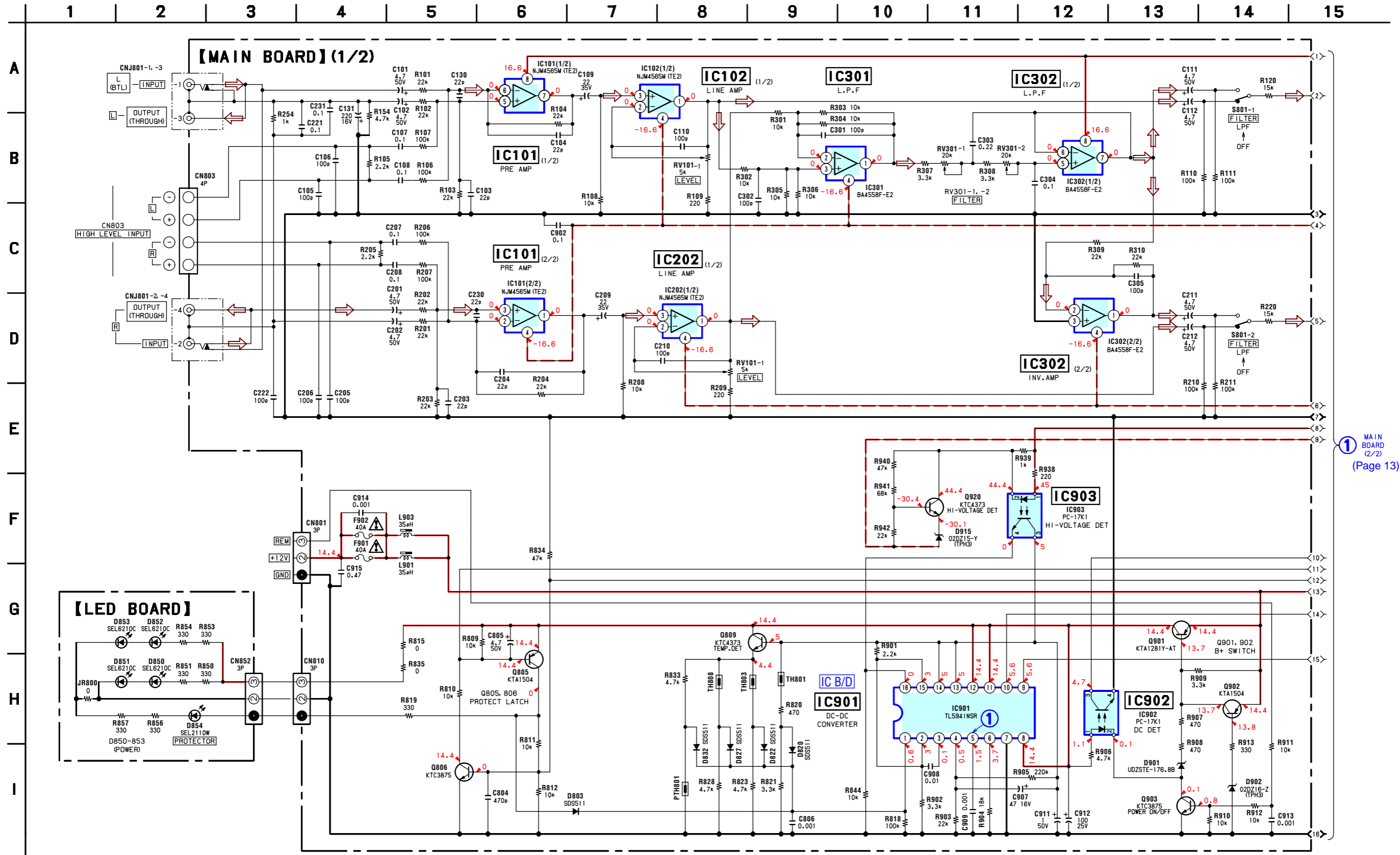

1 MAIN BOARD (2/2) (Page 13)

**Note:**  
The components identified by mark  $\triangle$  or dotted line with mark  $\triangle$  are critical for safety. Replace only with part number specified.

**Note:**  
Les composants identifiés par une marque  $\triangle$  sont critiques pour la sécurité. Ne les remplacer que par une pièce portant le numéro spécifié.

4-3. SCHEMATIC DIAGRAM — MAIN SECTION (2/2) —

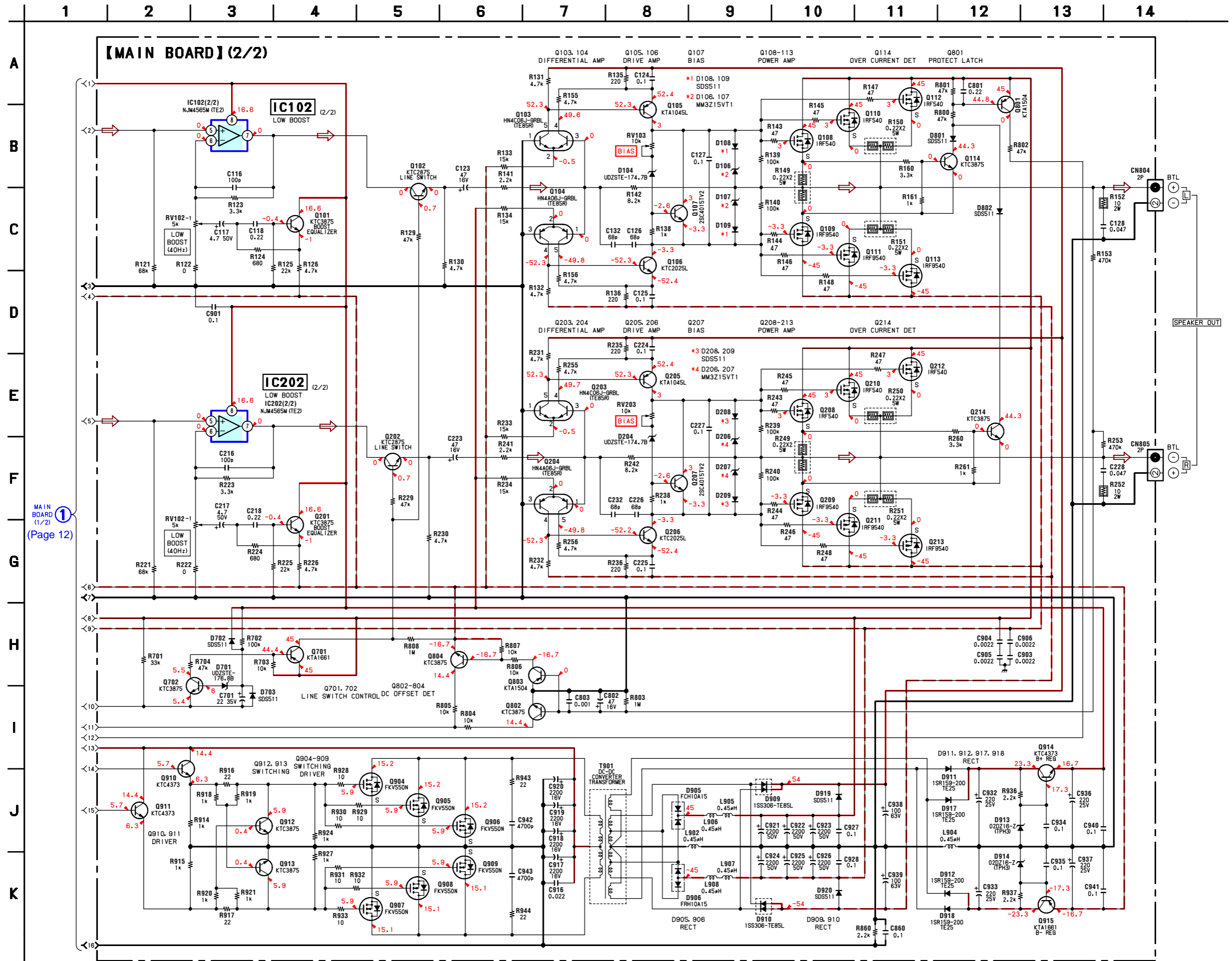



4-4. PRINTED WIRING BOARDS — MAIN SECTION — • Refer to page 15 for Semiconductor Location.

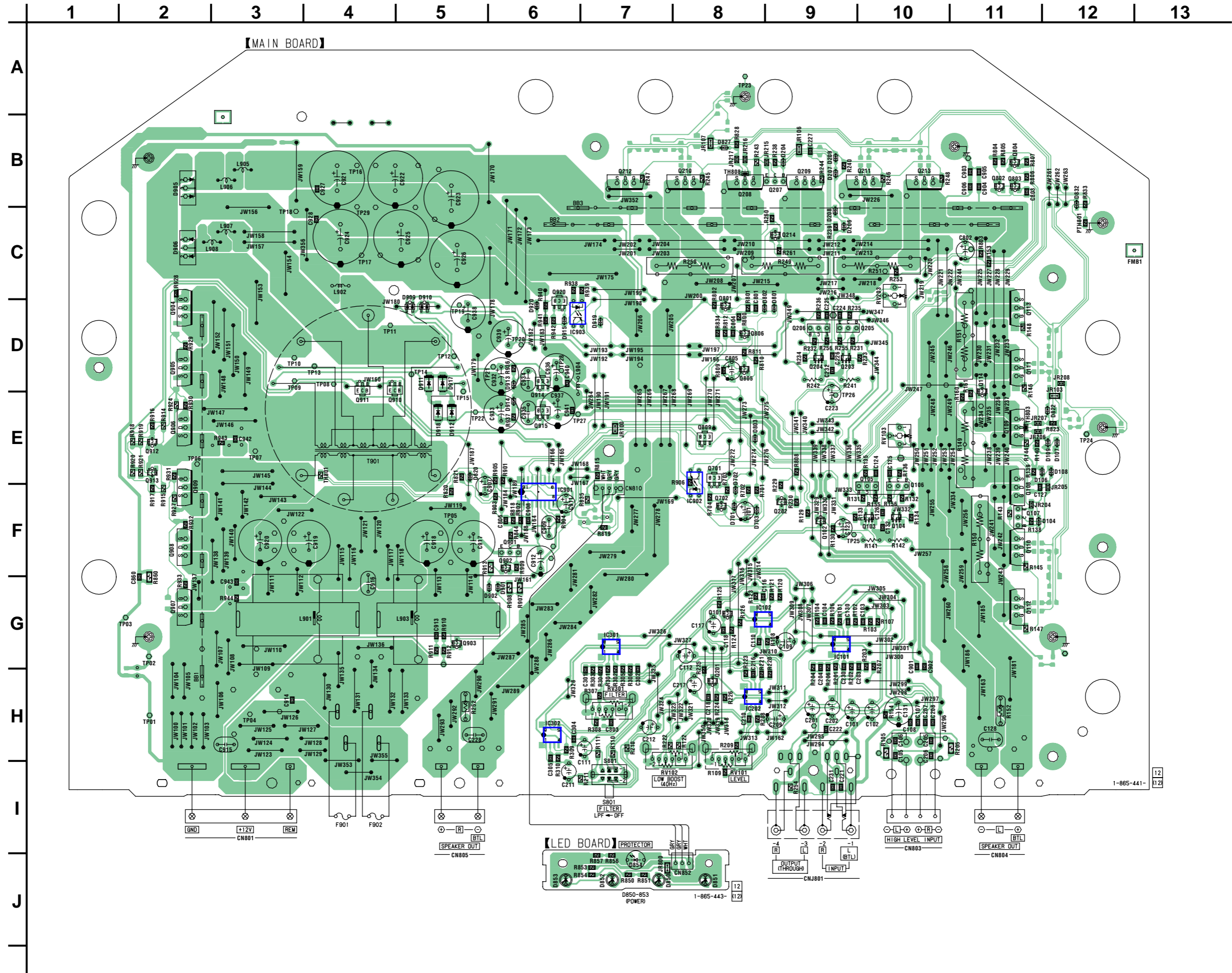



• Semiconductor Location (MAIN BOARD)

Ref. No.	Location	Ref. No.	Location
D104	F-11	Q103	F-10
D106	E-12	Q104	F-10
D107	E-12	Q105	E-10
D108	E-12	Q106	E-10
D109	E-12	Q107	F-11
D204	B-9	Q108	F-11
D206	C-9	Q109	E-11
D207	B-9	Q110	F-11
D208	C-9	Q111	D-11
D209	B-9	Q112	G-11
D701	F-8	Q113	D-11
D702	E-8	Q114	D-11
D703	F-8	Q201	H-8
D801	D-9	Q202	F-9
D802	D-8	Q203	D-9
D803	E-8	Q204	D-9
D820	E-5	Q205	D-10
D822	E-12	Q206	D-9
D827	B-8	Q207	B-9
D832	B-12	Q208	B-8
D850	J-7	Q209	B-9
D851	J-8	Q210	B-8
D852	J-7	Q211	B-10
D853	J-6	Q212	B-7
D854	J-7	Q213	B-10
D901	G-6	Q214	C-9
D902	G-6	Q701	E-8
D905	B-2	Q702	F-8
D906	C-2	Q801	D-8
D909	D-5	Q802	B-11
D910	D-5	Q803	B-11
D911	D-5	Q804	B-11
D912	E-5	Q805	D-8
D913	D-6	Q806	D-8
D914	E-6	Q809	E-8
D915	D-6	Q901	F-6
D917	D-5	Q902	F-6
D918	E-5	Q903	G-5
D919	D-7	Q904	D-2
D920	D-6	Q905	D-2
		Q906	E-2
IC101	G-9	Q907	G-2
IC102	G-8	Q908	F-2
IC202	H-8	Q909	F-2
IC301	G-7	Q910	E-4
IC302	H-6	Q911	E-4
IC901	F-6	Q912	E-2
IC902	F-8	Q913	E-2
IC903	D-6	Q914	E-6
		Q915	E-6
Q101	G-8	Q920	C-6
Q102	F-9		

**THIS NOTE IS COMMON FOR PRINTED WIRING BOARDS AND SCHEMATIC DIAGRAMS.**  
**(In addition to this, the necessary note is printed in each block.)**

**for schematic diagram:**

**Note:**





- All capacitors are in  $\mu\text{F}$  unless otherwise noted. (p: pF) 50 WV or less are not indicated except for electrolytics and tantalums.
- All resistors are in  $\Omega$  and  $\frac{1}{4}W$  or less unless otherwise specified.
- % : indicates tolerance.
-  : nonflammable resistor.
-  : panel designation.

**Note:**

The components identified by mark  $\triangle$  or dotted line with mark  $\triangle$  are critical for safety. Replace only with part number specified.



**Note:**

Les composants identifiés par une marque  $\triangle$  sont critiques pour la sécurité. Ne les remplacer que par une pièce portant le numéro spécifié.

-  : B+ Line.
-  : B- Line.
-  : adjustment for repair.
- Power voltage is dc 14.4V and fed with regulated dc power supply from +12V and REM terminals.
- Voltage and waveform are dc with respect to ground under no-signal condition.
- Voltages are taken with a VOM (Input impedance 10 M $\Omega$ ). Voltage variations may be noted due to normal production tolerances.
- Waveforms are taken with an oscilloscope. Voltage variations may be noted due to normal production tolerances.
- Circled numbers refer to waveforms.
- Signal path.
-  : AUDIO

**for printed wiring boards:**

**Note:**

-  : parts extracted from the component side.
-  : Pattern from the side which enables seeing.

• IC Block Diagram

IC901 TL5941NSR

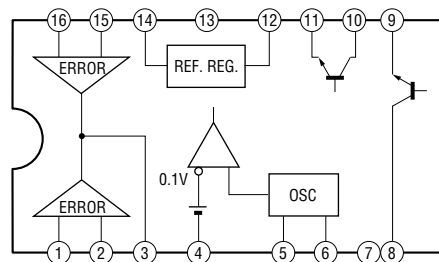

• Waveform

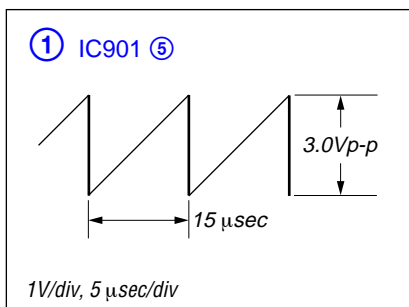





5-2. MAIN BOARD SECTION

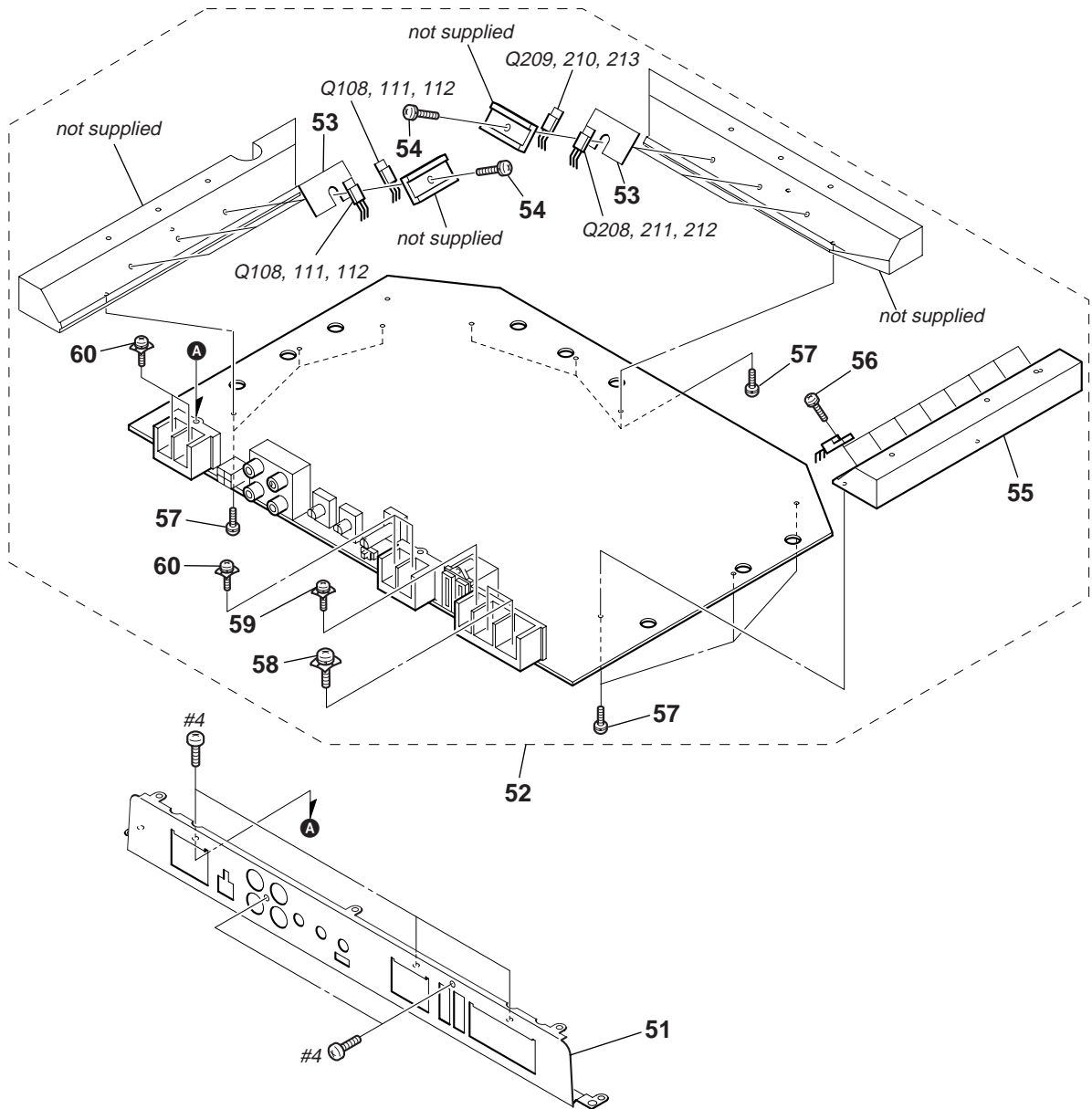

Ref. No.	Part No.	Description	Remark	Ref. No.	Part No.	Description	Remark
51	3-262-163-01	PANEL (FRONT)		Q110	X-3383-027-1	FET PAIR ASSY (N) (IRF540) (set of 3)	
52	A-1083-419-A	MAIN BOARD, COMPLETE		Q111	X-3383-028-1	FET PAIR ASSY (P) (IRF9540) (set of 3)	
53	3-238-413-01	SHEET (TR), INSULATING		Q112	X-3383-027-1	FET PAIR ASSY (N) (IRF540) (set of 3)	
54	3-225-183-12	SCREW (+PSW.TT.3XL)		Q113	X-3383-028-1	FET PAIR ASSY (P) (IRF9540) (set of 3)	
55	3-249-786-01	HEAT SINK (SUB.POWER)		Q208	X-3383-027-1	FET PAIR ASSY (N) (IRF540) (set of 3)	
56	3-225-183-32	SCREW (+PSW.TT.3XL)		Q209	X-3383-028-1	FET PAIR ASSY (P) (IRF9540) (set of 3)	
57	3-225-184-12	SCREW (+PS.TT.3XL)		Q210	X-3383-027-1	FET PAIR ASSY (N) (IRF540) (set of 3)	
58	3-253-537-01	SCREW (M5X11)		Q211	X-3383-028-1	FET PAIR ASSY (P) (IRF9540) (set of 3)	
59	3-912-431-01	SCREW (+P)		Q212	X-3383-027-1	FET PAIR ASSY (N) (IRF540) (set of 3)	
60	3-912-432-01	SCREW (+B)		Q213	X-3383-028-1	FET PAIR ASSY (P) (IRF9540) (set of 3)	
Q108	X-3383-027-1	FET PAIR ASSY (N) (IRF540) (set of 3)		#4	7-685-646-79	SCREW +P 3X8 TYPE2 NON-SLIT	
Q109	X-3383-028-1	FET PAIR ASSY (P) (IRF9540) (set of 3)					

**SECTION 6  
ELECTRICAL PARTS LIST**

**MAIN**

**NOTE:**

- Due to standardization, replacements in the parts list may be different from the parts specified in the diagrams or the components used on the set.
- **RESISTORS**  
All resistors are in ohms.  
METAL: Metal-film resistor.  
METAL OXIDE: Metal oxide-film resistor.  
F: nonflammable

- Items marked "\*\*\*" are not stocked since they are seldom required for routine service. Some delay should be anticipated when ordering these items.
- **SEMICONDUCTORS**  
In each case, u :  $\mu$ , for example:  
uA.. :  $\mu$ A.. uPA.. :  $\mu$ PA..  
uPB.. :  $\mu$ PB.. uPC.. :  $\mu$ PC.. uPD.. :  $\mu$ PD..
- **CAPACITORS**  
uF :  $\mu$ F
- **COILS**  
uH :  $\mu$ H

The components identified by mark  $\Delta$  or dotted line with mark  $\Delta$  are critical for safety. Replace only with part number specified.

Les composants identifiés par une marque  $\Delta$  sont critiques pour la sécurité. Ne les remplacer que par une pièce portant le numéro spécifié.

When indicating parts by reference number, please include the board.

Ref. No.	Part No.	Description	Remark	Ref. No.	Part No.	Description	Remark
	A-1083-419-A	MAIN BOARD, COMPLETE *****		C208	1-107-826-11	CERAMIC CHIP 0.1uF 10%	16V
	3-225-183-12	SCREW (+PSW.TT.3XL)		C209	1-126-796-11	ELECT 22uF 20%	50V
	3-225-183-32	SCREW (+PSW.TT.3XL)		C210	1-162-927-11	CERAMIC CHIP 100PF 5%	50V
	3-225-184-12	SCREW (+PS.TT.3XL)		C211	1-126-794-11	ELECT 4.7uF 20%	50V
	3-238-413-01	SHEET (TR), INSULATING		C212	1-126-794-11	ELECT 4.7uF 20%	50V
	3-249-786-01	HEAT SINK (SUB.POWER)		C216	1-162-927-11	CERAMIC CHIP 100PF 5%	50V
	3-253-537-01	SCREW (M5X11)		C217	1-126-794-11	ELECT 4.7uF 20%	50V
	3-912-431-01	SCREW (+P)		C218	1-127-715-11	CERAMIC CHIP 0.22uF 10%	16V
	3-912-432-01	SCREW (+B)		C221	1-115-339-11	CERAMIC CHIP 0.1uF 10%	50V
	7-685-646-79	SCREW +P 3X8 TYPE2 NON-SLIT		C222	1-162-927-11	CERAMIC CHIP 100PF 5%	50V
		< CAPACITOR >		C223	1-126-786-11	ELECT 47uF 20%	16V
C101	1-126-794-11	ELECT 4.7uF 20%	50V	C224	1-107-826-11	CERAMIC CHIP 0.1uF 10%	16V
C102	1-126-794-11	ELECT 4.7uF 20%	50V	C225	1-107-826-11	CERAMIC CHIP 0.1uF 10%	16V
C103	1-162-919-11	CERAMIC CHIP 22PF 5%	50V	C226	1-162-925-11	CERAMIC CHIP 68PF 5%	50V
C104	1-162-919-11	CERAMIC CHIP 22PF 5%	50V	C227	1-107-826-11	CERAMIC CHIP 0.1uF 10%	16V
C105	1-163-251-11	CERAMIC CHIP 100PF 5%	50V	C228	1-137-374-11	MYLAR 0.047uF 5%	50V
C106	1-163-251-11	CERAMIC CHIP 100PF 5%	50V	C230	1-162-919-11	CERAMIC CHIP 22PF 5%	50V
C107	1-107-826-11	CERAMIC CHIP 0.1uF 10%	16V	C231	1-115-339-11	CERAMIC CHIP 0.1uF 10%	50V
C108	1-107-826-11	CERAMIC CHIP 0.1uF 10%	16V	C232	1-162-925-11	CERAMIC CHIP 68PF 5%	50V
C109	1-126-796-11	ELECT 22uF 20%	50V	C301	1-162-927-11	CERAMIC CHIP 100PF 5%	50V
C110	1-162-927-11	CERAMIC CHIP 100PF 5%	50V	C302	1-162-927-11	CERAMIC CHIP 100PF 5%	50V
C111	1-126-794-11	ELECT 4.7uF 20%	50V	C303	1-127-715-11	CERAMIC CHIP 0.22uF 10%	16V
C112	1-126-794-11	ELECT 4.7uF 20%	50V	C304	1-107-826-11	CERAMIC CHIP 0.1uF 10%	16V
C116	1-162-927-11	CERAMIC CHIP 100PF 5%	50V	C305	1-162-927-11	CERAMIC CHIP 100PF 5%	50V
C117	1-126-794-11	ELECT 4.7uF 20%	50V	C701	1-126-796-11	ELECT 22uF 20%	50V
C118	1-127-715-11	CERAMIC CHIP 0.22uF 10%	16V	C801	1-127-715-11	CERAMIC CHIP 0.22uF 10%	16V
C123	1-126-786-11	ELECT 47uF 20%	16V	C802	1-126-786-11	ELECT 47uF 20%	16V
C124	1-107-826-11	CERAMIC CHIP 0.1uF 10%	16V	C803	1-162-964-11	CERAMIC CHIP 0.001uF 10%	50V
C125	1-107-826-11	CERAMIC CHIP 0.1uF 10%	16V	C804	1-162-962-11	CERAMIC CHIP 470PF 10%	50V
C126	1-162-925-11	CERAMIC CHIP 68PF 5%	50V	C805	1-126-794-11	ELECT 4.7uF 20%	50V
C127	1-107-826-11	CERAMIC CHIP 0.1uF 10%	16V	C806	1-162-964-11	CERAMIC CHIP 0.001uF 10%	50V
C128	1-137-374-11	MYLAR 0.047uF 5%	50V	C860	1-107-826-11	CERAMIC CHIP 0.1uF 10%	16V
C130	1-162-919-11	CERAMIC CHIP 22PF 5%	50V	C901	1-115-339-11	CERAMIC CHIP 0.1uF 10%	50V
C131	1-128-499-11	ELECT 220uF 20%	16V	C902	1-115-339-11	CERAMIC CHIP 0.1uF 10%	50V
C132	1-162-925-11	CERAMIC CHIP 68PF 5%	50V	C903	1-164-161-11	CERAMIC CHIP 0.0022uF 10%	50V
C201	1-126-794-11	ELECT 4.7uF 20%	50V	C904	1-164-161-11	CERAMIC CHIP 0.0022uF 10%	50V
C202	1-126-794-11	ELECT 4.7uF 20%	50V	C905	1-164-161-11	CERAMIC CHIP 0.0022uF 10%	50V
C203	1-162-919-11	CERAMIC CHIP 22PF 5%	50V	C906	1-164-161-11	CERAMIC CHIP 0.0022uF 10%	50V
C204	1-162-919-11	CERAMIC CHIP 22PF 5%	50V	C907	1-126-786-11	ELECT 47uF 20%	16V
C205	1-163-251-11	CERAMIC CHIP 100PF 5%	50V	C908	1-162-970-11	CERAMIC CHIP 0.01uF 10%	25V
C206	1-163-251-11	CERAMIC CHIP 100PF 5%	50V	C909	1-130-471-00	MYLAR 0.001uF 5%	50V
C207	1-107-826-11	CERAMIC CHIP 0.1uF 10%	16V	C911	1-126-960-11	ELECT 1uF 20%	50V
				C912	1-128-126-11	ELECT 100uF 20%	25V
				C913	1-162-964-11	CERAMIC CHIP 0.001uF 10%	50V

Ref. No.	Part No.	Description	Remark	Ref. No.	Part No.	Description	Remark
C914	1-162-964-11	CERAMIC CHIP	0.001uF 10% 50V	D803	8-719-080-34	DIODE SDS511	
C915	1-137-194-81	FILM	0.47uF 5% 50V	D820	8-719-080-34	DIODE SDS511	
C916	1-137-372-11	MYLAR	0.022uF 5% 50V	D822	8-719-080-34	DIODE SDS511	
C917	1-128-951-21	ELECT	2200uF 20% 16V	D827	8-719-080-34	DIODE SDS511	
C918	1-128-951-21	ELECT	2200uF 20% 16V	D832	8-719-080-34	DIODE SDS511	
C919	1-128-951-21	ELECT	2200uF 20% 16V	D901	8-719-978-33	DIODE DTZ-TT11-6.8B	
C920	1-128-951-21	ELECT	2200uF 20% 16V	D902	8-719-065-46	DIODE 02DZ16-Z(TPH3)	
C921	1-100-199-31	ELECT	2200uF 20% 50V	D905	8-719-079-00	DIODE FCH10A15	
C922	1-100-199-31	ELECT	2200uF 20% 50V	D906	8-719-079-01	DIODE FRH10A15	
C923	1-100-199-31	ELECT	2200uF 20% 50V	D909	8-719-054-55	DIODE 1SS306-TE85L	
C924	1-100-199-31	ELECT	2200uF 20% 50V	D910	8-719-054-55	DIODE 1SS306-TE85L	
C925	1-100-199-31	ELECT	2200uF 20% 50V	D911	8-719-079-92	DIODE 1SR159-200TE25	
C926	1-100-199-31	ELECT	2200uF 20% 50V	D912	8-719-079-92	DIODE 1SR159-200TE25	
C927	1-115-339-11	CERAMIC CHIP	0.1uF 10% 50V	D913	8-719-065-46	DIODE 02DZ16-Z(TPH3)	
C928	1-115-339-11	CERAMIC CHIP	0.1uF 10% 50V	D914	8-719-065-46	DIODE 02DZ16-Z(TPH3)	
C932	1-104-666-11	ELECT	220uF 20% 25V	D915	8-719-065-42	DIODE 02DZ15-Y(TPH3)	
C933	1-104-666-11	ELECT	220uF 20% 25V	D917	8-719-079-92	DIODE 1SR159-200TE25	
C934	1-130-495-00	MYLAR	0.1uF 5% 50V	D918	8-719-079-92	DIODE 1SR159-200TE25	
C935	1-130-495-00	MYLAR	0.1uF 5% 50V	D919	8-719-080-34	DIODE SDS511	
C936	1-104-666-11	ELECT	220uF 20% 25V	D920	8-719-080-34	DIODE SDS511	
C937	1-104-666-11	ELECT	220uF 20% 25V			< FUSE >	
C938	1-128-576-11	ELECT	100uF 20% 63V	△F901	1-533-743-11	FUSE (BLADE TYPE) (AUTO FUSE) (40A)	
C939	1-128-576-11	ELECT	100uF 20% 63V	△F902	1-533-743-11	FUSE (BLADE TYPE) (AUTO FUSE) (40A)	
C940	1-115-339-11	CERAMIC CHIP	0.1uF 10% 50V			< IC >	
C941	1-115-339-11	CERAMIC CHIP	0.1uF 10% 50V	IC101	8-759-710-97	IC NJM4565M-D	
C942	1-162-968-11	CERAMIC CHIP	0.0047uF 10% 50V	IC102	8-759-710-97	IC NJM4565M-D	
C943	1-162-968-11	CERAMIC CHIP	0.0047uF 10% 50V	IC202	8-759-710-97	IC NJM4565M-D	
		< TERMINAL BOARD >		IC301	8-759-909-71	IC BA4558F	
CN801	1-694-983-11	TERMINAL BOARD (3P+FUSE)	(REM,+12V,GND,40A,40A)	IC302	8-759-909-71	IC BA4558F	
CN804	1-694-984-11	TERMINAL BOARD (2P) (SPEAKER OUT (L))		IC901	6-703-643-01	IC TL594INSR	
CN805	1-694-984-11	TERMINAL BOARD (2P) (SPEAKER OUT (R))				< PHOTO TRANSISTOR >	
		< CONNECTOR >		IC902	6-600-354-01	PHOTO TRANSISTOR PC-17K1	
* CN803	1-691-785-11	PIN, CONNECTOR (PC BOARD) 4P	(HIGH LEVEL INPUT)	IC903	6-600-354-01	PHOTO TRANSISTOR PC-17K1	
CN810	1-506-468-11	PIN, CONNECTOR 3P				< JUMPER RESISTOR >	
		< JACK >		JR100	1-216-296-11	SHORT CHIP 0	
CNJ801	1-779-078-41	JACK, PIN 4P (INPUT,OUTPUT (THROUGH))		JR103	1-216-296-11	SHORT CHIP 0	
		< DIODE >		JR106	1-216-296-11	SHORT CHIP 0	
D104	8-719-083-60	DIODE UDZSTE-174.7B		JR107	1-216-296-11	SHORT CHIP 0	
D106	8-719-082-03	DIODE MM3Z15VT1		JR204	1-216-295-11	SHORT CHIP 0	
D107	8-719-082-03	DIODE MM3Z15VT1		JR205	1-216-295-11	SHORT CHIP 0	
D108	8-719-080-34	DIODE SDS511		JR206	1-216-295-11	SHORT CHIP 0	
D109	8-719-080-34	DIODE SDS511		JR207	1-216-295-11	SHORT CHIP 0	
D204	8-719-083-60	DIODE UDZSTE-174.7B		JR208	1-216-295-11	SHORT CHIP 0	
D206	8-719-082-03	DIODE MM3Z15VT1		JR215	1-216-295-11	SHORT CHIP 0	
D207	8-719-082-03	DIODE MM3Z15VT1		JR216	1-216-295-11	SHORT CHIP 0	
D208	8-719-080-34	DIODE SDS511		JR217	1-216-295-11	SHORT CHIP 0	
D209	8-719-080-34	DIODE SDS511				< COIL >	
D701	8-719-978-33	DIODE DTZ-TT11-6.8B		L901	1-456-139-12	INDUCTOR 35uH	
D702	8-719-080-34	DIODE SDS511		L902	1-410-396-71	FERRITE 0.45uH	
D703	8-719-080-34	DIODE SDS511		L903	1-456-139-12	INDUCTOR 35uH	
D801	8-719-080-34	DIODE SDS511		L904	1-410-396-71	FERRITE 0.45uH	
D802	8-719-080-34	DIODE SDS511		L905	1-410-396-71	FERRITE 0.45uH	

The components identified by mark △ or dotted line with mark △ are critical for safety. Replace only with part number specified.	Les composants identifiés par une marque △ sont critiques pour la sécurité. Ne les remplacer que par une pièce portant le numéro spécifié.
--	--

# XM-SD22X

MAIN

Ref. No.	Part No.	Description	Remark	Ref. No.	Part No.	Description	Remark
L906	1-410-396-71	FERRITE	0.45uH	Q914	6-550-693-01	TRANSISTOR	KTC4373
L907	1-410-396-71	FERRITE	0.45uH	Q915	6-550-690-01	TRANSISTOR	KTA1661
L908	1-410-396-71	FERRITE	0.45uH	Q920	6-550-693-01	TRANSISTOR	KTC4373
		< THERMISTOR (POSITIVE) >				< RESISTOR >	
PTH801	1-805-163-21	THERMISTOR, POSITIVE		R101	1-216-837-11	METAL CHIP	22K 5% 1/10W
		< TRANSISTOR >		R102	1-216-837-11	METAL CHIP	22K 5% 1/10W
Q101	8-729-034-51	TRANSISTOR	KTC3875	R103	1-216-837-11	METAL CHIP	22K 5% 1/10W
Q102	6-550-686-01	TRANSISTOR	KTC2875-B-RTK	R104	1-216-837-11	METAL CHIP	22K 5% 1/10W
Q103	6-550-031-01	TRANSISTOR	HN4C06J-GRBL(TE85R)	R105	1-216-206-00	RES-CHIP	2.2K 5% 1/8W
Q104	6-550-032-01	TRANSISTOR	HN4A06J-GRBL(TE85R)	R106	1-216-845-11	METAL CHIP	100K 5% 1/10W
Q105	6-550-691-01	TRANSISTOR	KTA1045L-Y	R107	1-216-845-11	METAL CHIP	100K 5% 1/10W
Q106	6-550-692-01	TRANSISTOR	KTC2025L-Y	R108	1-216-833-11	METAL CHIP	10K 5% 1/10W
Q107	8-729-041-66	TRANSISTOR	2SC4015TV2	R109	1-216-033-00	RES-CHIP	220 5% 1/10W
Q108	X-3383-027-1	FET PAIR ASSY (N)	(IRF540) (set of 3)	R110	1-216-845-11	METAL CHIP	100K 5% 1/10W
Q109	X-3383-028-1	FET PAIR ASSY (P)	(IRF9540) (set of 3)	R111	1-216-845-11	METAL CHIP	100K 5% 1/10W
Q110	X-3383-027-1	FET PAIR ASSY (N)	(IRF540) (set of 3)	R120	1-216-077-11	RES-CHIP	15K 5% 1/10W
Q111	X-3383-028-1	FET PAIR ASSY (P)	(IRF9540) (set of 3)	R121	1-216-843-11	METAL CHIP	68K 5% 1/10W
Q112	X-3383-027-1	FET PAIR ASSY (N)	(IRF540) (set of 3)	R122	1-216-295-11	SHORT CHIP	0
Q113	X-3383-028-1	FET PAIR ASSY (P)	(IRF9540) (set of 3)	R123	1-216-827-11	METAL CHIP	3.3K 5% 1/10W
Q114	8-729-034-51	TRANSISTOR	KTC3875	R124	1-216-045-00	RES-CHIP	680 5% 1/10W
Q201	8-729-034-51	TRANSISTOR	KTC3875	R125	1-216-837-11	METAL CHIP	22K 5% 1/10W
Q202	6-550-686-01	TRANSISTOR	KTC2875-B-RTK	R126	1-216-829-11	METAL CHIP	4.7K 5% 1/10W
Q203	6-550-031-01	TRANSISTOR	HN4C06J-GRBL(TE85R)	R129	1-216-841-11	METAL CHIP	47K 5% 1/10W
Q204	6-550-032-01	TRANSISTOR	HN4A06J-GRBL(TE85R)	R130	1-216-829-11	METAL CHIP	4.7K 5% 1/10W
Q205	6-550-691-01	TRANSISTOR	KTA1045L-Y	R131	1-216-829-11	METAL CHIP	4.7K 5% 1/10W
Q206	6-550-692-01	TRANSISTOR	KTC2025L-Y	R132	1-216-829-11	METAL CHIP	4.7K 5% 1/10W
Q207	8-729-041-66	TRANSISTOR	2SC4015TV2	R133	1-216-077-11	RES-CHIP	15K 5% 1/10W
Q208	X-3383-027-1	FET PAIR ASSY (N)	(IRF540) (set of 3)	R134	1-216-077-11	RES-CHIP	15K 5% 1/10W
Q209	X-3383-028-1	FET PAIR ASSY (P)	(IRF9540) (set of 3)	R135	1-216-033-00	RES-CHIP	220 5% 1/10W
Q210	X-3383-027-1	FET PAIR ASSY (N)	(IRF540) (set of 3)	R136	1-216-033-00	RES-CHIP	220 5% 1/10W
Q211	X-3383-028-1	FET PAIR ASSY (P)	(IRF9540) (set of 3)	R138	1-216-821-11	METAL CHIP	1K 5% 1/10W
Q212	X-3383-027-1	FET PAIR ASSY (N)	(IRF540) (set of 3)	R139	1-216-845-11	METAL CHIP	100K 5% 1/10W
Q213	X-3383-028-1	FET PAIR ASSY (P)	(IRF9540) (set of 3)	R140	1-216-845-11	METAL CHIP	100K 5% 1/10W
Q214	8-729-034-51	TRANSISTOR	KTC3875	R141	1-249-421-11	CARBON	2.2K 5% 1/4W
Q701	6-550-690-01	TRANSISTOR	KTA1661	R142	1-249-428-11	CARBON	8.2K 5% 1/4W
Q702	8-729-034-51	TRANSISTOR	KTC3875	R143	1-216-017-11	RES-CHIP	47 5% 1/10W
Q801	8-729-034-50	TRANSISTOR	KTA1504	R144	1-216-017-11	RES-CHIP	47 5% 1/10W
Q802	8-729-034-51	TRANSISTOR	KTC3875	R145	1-216-017-11	RES-CHIP	47 5% 1/10W
Q803	8-729-034-50	TRANSISTOR	KTA1504	R146	1-216-017-11	RES-CHIP	47 5% 1/10W
Q804	8-729-034-51	TRANSISTOR	KTC3875	R147	1-216-017-11	RES-CHIP	47 5% 1/10W
Q805	8-729-034-50	TRANSISTOR	KTA1504	R148	1-216-017-11	RES-CHIP	47 5% 1/10W
Q806	8-729-034-51	TRANSISTOR	KTC3875	R149	1-234-499-11	ENCAPSULATED COMPONENT	0.22X2 5W
Q809	6-550-693-01	TRANSISTOR	KTC4373	R150	1-234-499-11	ENCAPSULATED COMPONENT	0.22X2 5W
Q901	8-729-052-82	TRANSISTOR	KTA1281Y-AT	R151	1-234-499-11	ENCAPSULATED COMPONENT	0.22X2 5W
Q902	8-729-034-50	TRANSISTOR	KTA1504	R152	1-215-880-31	METAL OXIDE	10 5% 2W F
Q903	8-729-034-51	TRANSISTOR	KTC3875	R153	1-216-853-11	METAL CHIP	470K 5% 1/10W
Q904	6-550-341-01	FET	FKV550N	R154	1-216-065-11	RES-CHIP	4.7K 5% 1/10W
Q905	6-550-341-01	FET	FKV550N	R155	1-216-829-11	METAL CHIP	4.7K 5% 1/10W
Q906	6-550-341-01	FET	FKV550N	R156	1-216-829-11	METAL CHIP	4.7K 5% 1/10W
Q907	6-550-341-01	FET	FKV550N	R160	1-216-827-11	METAL CHIP	3.3K 5% 1/10W
Q908	6-550-341-01	FET	FKV550N	R161	1-216-821-11	METAL CHIP	1K 5% 1/10W
Q909	6-550-341-01	FET	FKV550N	R201	1-216-837-11	METAL CHIP	22K 5% 1/10W
Q910	6-550-693-01	TRANSISTOR	KTC4373	R202	1-216-837-11	METAL CHIP	22K 5% 1/10W
Q911	6-550-693-01	TRANSISTOR	KTC4373	R203	1-216-837-11	METAL CHIP	22K 5% 1/10W
Q912	8-729-034-51	TRANSISTOR	KTC3875	R204	1-216-837-11	METAL CHIP	22K 5% 1/10W
Q913	8-729-034-51	TRANSISTOR	KTC3875	R205	1-216-206-00	RES-CHIP	2.2K 5% 1/8W
				R206	1-216-845-11	METAL CHIP	100K 5% 1/10W

Ref. No.	Part No.	Description			Remark	Ref. No.	Part No.	Description			Remark
R207	1-216-845-11	METAL CHIP	100K	5%	1/10W	R803	1-216-857-11	METAL CHIP	1M	5%	1/10W
R208	1-216-833-11	METAL CHIP	10K	5%	1/10W	R804	1-216-833-11	METAL CHIP	10K	5%	1/10W
R209	1-216-033-00	RES-CHIP	220	5%	1/10W	R805	1-216-833-11	METAL CHIP	10K	5%	1/10W
R210	1-216-845-11	METAL CHIP	100K	5%	1/10W	R806	1-216-833-11	METAL CHIP	10K	5%	1/10W
R211	1-216-845-11	METAL CHIP	100K	5%	1/10W	R807	1-216-833-11	METAL CHIP	10K	5%	1/10W
R220	1-216-077-11	RES-CHIP	15K	5%	1/10W	R808	1-216-857-11	METAL CHIP	1M	5%	1/10W
R221	1-216-843-11	METAL CHIP	68K	5%	1/10W	R809	1-216-833-11	METAL CHIP	10K	5%	1/10W
R222	1-216-295-11	SHORT CHIP	0			R810	1-216-833-11	METAL CHIP	10K	5%	1/10W
R223	1-216-827-11	METAL CHIP	3.3K	5%	1/10W	R811	1-216-833-11	METAL CHIP	10K	5%	1/10W
R224	1-216-045-00	RES-CHIP	680	5%	1/10W	R812	1-216-833-11	METAL CHIP	10K	5%	1/10W
R225	1-216-837-11	METAL CHIP	22K	5%	1/10W	R815	1-216-295-11	SHORT CHIP	0		
R226	1-216-829-11	METAL CHIP	4.7K	5%	1/10W	R818	1-216-845-11	METAL CHIP	100K	5%	1/10W
R229	1-216-841-11	METAL CHIP	47K	5%	1/10W	R819	1-216-815-11	METAL CHIP	330	5%	1/10W
R230	1-216-829-11	METAL CHIP	4.7K	5%	1/10W	R820	1-216-817-11	METAL CHIP	470	5%	1/10W
R231	1-216-829-11	METAL CHIP	4.7K	5%	1/10W	R821	1-216-827-11	METAL CHIP	3.3K	5%	1/10W
R232	1-216-829-11	METAL CHIP	4.7K	5%	1/10W	R823	1-216-828-11	METAL CHIP	3.9K	5%	1/10W
R233	1-216-077-11	RES-CHIP	15K	5%	1/10W	R828	1-216-828-11	METAL CHIP	3.9K	5%	1/10W
R234	1-216-077-11	RES-CHIP	15K	5%	1/10W	R833	1-216-829-11	METAL CHIP	4.7K	5%	1/10W
R235	1-216-033-00	RES-CHIP	220	5%	1/10W	R834	1-216-841-11	METAL CHIP	47K	5%	1/10W
R236	1-216-033-00	RES-CHIP	220	5%	1/10W	R835	1-216-295-11	SHORT CHIP	0		
R238	1-216-821-11	METAL CHIP	1K	5%	1/10W	R844	1-216-833-11	METAL CHIP	10K	5%	1/10W
R239	1-216-845-11	METAL CHIP	100K	5%	1/10W	R860	1-216-206-00	RES-CHIP	2.2K	5%	1/8W
R240	1-216-845-11	METAL CHIP	100K	5%	1/10W	R901	1-216-825-11	METAL CHIP	2.2K	5%	1/10W
R241	1-249-421-11	CARBON	2.2K	5%	1/4W	R902	1-216-827-11	METAL CHIP	3.3K	5%	1/10W
R242	1-249-428-11	CARBON	8.2K	5%	1/4W	R903	1-216-837-11	METAL CHIP	22K	5%	1/10W
R243	1-216-017-11	RES-CHIP	47	5%	1/10W	R904	1-216-836-11	METAL CHIP	18K	5%	1/10W
R244	1-216-017-11	RES-CHIP	47	5%	1/10W	R905	1-216-849-11	METAL CHIP	220K	5%	1/10W
R245	1-216-017-11	RES-CHIP	47	5%	1/10W	R906	1-216-065-11	RES-CHIP	4.7K	5%	1/10W
R246	1-216-017-11	RES-CHIP	47	5%	1/10W	R907	1-216-190-00	RES-CHIP	470	5%	1/8W
R247	1-216-017-11	RES-CHIP	47	5%	1/10W	R908	1-216-190-00	RES-CHIP	470	5%	1/8W
R248	1-216-017-11	RES-CHIP	47	5%	1/10W	R909	1-216-061-11	RES-CHIP	3.3K	5%	1/10W
R249	1-234-499-11	ENCAPSULATED COMPONENT 0.22X2 5W				R910	1-216-073-00	RES-CHIP	10K	5%	1/10W
R250	1-234-499-11	ENCAPSULATED COMPONENT 0.22X2 5W				R911	1-216-073-00	RES-CHIP	10K	5%	1/10W
R251	1-234-499-11	ENCAPSULATED COMPONENT 0.22X2 5W				R912	1-216-073-00	RES-CHIP	10K	5%	1/10W
R252	1-215-880-31	METAL OXIDE	10	5%	2W F	R913	1-216-186-00	RES-CHIP	330	5%	1/8W
R253	1-216-853-11	METAL CHIP	470K	5%	1/10W	R914	1-216-049-11	RES-CHIP	1K	5%	1/10W
R254	1-216-049-11	RES-CHIP	1K	5%	1/10W	R915	1-216-049-11	RES-CHIP	1K	5%	1/10W
R255	1-216-829-11	METAL CHIP	4.7K	5%	1/10W	R916	1-216-009-11	RES-CHIP	22	5%	1/10W
R256	1-216-829-11	METAL CHIP	4.7K	5%	1/10W	R917	1-216-009-11	RES-CHIP	22	5%	1/10W
R260	1-216-827-11	METAL CHIP	3.3K	5%	1/10W	R918	1-216-049-11	RES-CHIP	1K	5%	1/10W
R261	1-216-821-11	METAL CHIP	1K	5%	1/10W	R919	1-216-049-11	RES-CHIP	1K	5%	1/10W
R301	1-216-833-11	METAL CHIP	10K	5%	1/10W	R920	1-216-049-11	RES-CHIP	1K	5%	1/10W
R302	1-216-833-11	METAL CHIP	10K	5%	1/10W	R921	1-216-049-11	RES-CHIP	1K	5%	1/10W
R303	1-216-833-11	METAL CHIP	10K	5%	1/10W	R924	1-216-049-11	RES-CHIP	1K	5%	1/10W
R304	1-216-833-11	METAL CHIP	10K	5%	1/10W	R927	1-216-049-11	RES-CHIP	1K	5%	1/10W
R305	1-216-833-11	METAL CHIP	10K	5%	1/10W	R928	1-216-001-00	RES-CHIP	10	5%	1/10W
R306	1-216-833-11	METAL CHIP	10K	5%	1/10W	R929	1-216-001-00	RES-CHIP	10	5%	1/10W
R307	1-216-827-11	METAL CHIP	3.3K	5%	1/10W	R930	1-216-001-00	RES-CHIP	10	5%	1/10W
R308	1-216-827-11	METAL CHIP	3.3K	5%	1/10W	R931	1-216-001-00	RES-CHIP	10	5%	1/10W
R309	1-216-837-11	METAL CHIP	22K	5%	1/10W	R932	1-216-001-00	RES-CHIP	10	5%	1/10W
R310	1-216-837-11	METAL CHIP	22K	5%	1/10W	R933	1-216-001-00	RES-CHIP	10	5%	1/10W
R701	1-216-839-11	METAL CHIP	33K	5%	1/10W	R936	1-216-825-11	METAL CHIP	2.2K	5%	1/10W
R702	1-216-845-11	METAL CHIP	100K	5%	1/10W	R937	1-216-825-11	METAL CHIP	2.2K	5%	1/10W
R703	1-216-833-11	METAL CHIP	10K	5%	1/10W	R938	1-216-033-00	RES-CHIP	220	5%	1/10W
R704	1-216-841-11	METAL CHIP	47K	5%	1/10W	R939	1-216-821-11	METAL CHIP	1K	5%	1/10W
R800	1-216-841-11	METAL CHIP	47K	5%	1/10W	R940	1-216-089-11	RES-CHIP	47K	5%	1/10W
R801	1-216-841-11	METAL CHIP	47K	5%	1/10W	R941	1-216-843-11	METAL CHIP	68K	5%	1/10W
R802	1-216-841-11	METAL CHIP	47K	5%	1/10W	R942	1-216-837-11	METAL CHIP	22K	5%	1/10W

# XM-SD22X

**MAIN** **LED**

Ref. No.	Part No.	Description	Remark
R943	1-216-009-11	RES-CHIP 22 5%	1/10W
R944	1-216-009-11	RES-CHIP 22 5%	1/10W
< VARIABLE RESISTOR >			
RV101	1-227-558-11	RES, VAR, CARBON 5KX2 (LEVEL)	
RV102	1-227-558-11	RES, VAR, CARBON 5KX2 (LOW BOOST (40Hz))	
RV301	1-227-557-11	RES, VAR, CARBON 20KX2 (FILTER)	
< CERMET RESISTOR >			
RV103	1-241-764-11	RES, ADJ, CERMET 10K	
RV203	1-241-764-11	RES, ADJ, CERMET 10K	
< SWITCH >			
S801	1-692-990-21	SWITCH, SLIDE (FILTER)	
< TRANSFORMER >			
T901	1-439-635-21	TRANSFORMER, DC-DC CONVERTER	
< THERMISTOR (NEGATIVE) >			
TH801	1-804-301-11	THERMISTOR, CHIP (NEGATIVE)	
TH803	1-804-301-11	THERMISTOR, CHIP (NEGATIVE)	
TH808	1-804-301-11	THERMISTOR, CHIP (NEGATIVE)	
*****			
LED BOARD			
*****			
< DIODE >			
D850	6-501-118-01	LED SEL6E10C-STP5 (POWER)	
D851	6-501-118-01	LED SEL6E10C-STP5 (POWER)	
D852	6-501-118-01	LED SEL6E10C-STP5 (POWER)	
D853	6-501-118-01	LED SEL6E10C-STP5 (POWER)	
D854	6-501-117-01	LED SEL2110W-TP3 (PROTECTOR)	
< JUMPER RESISTOR >			
JR800	1-216-296-11	SHORT CHIP 0	
< RESISTOR >			
R850	1-216-815-11	METAL CHIP 330 5%	1/10W
R851	1-216-815-11	METAL CHIP 330 5%	1/10W
R853	1-216-815-11	METAL CHIP 330 5%	1/10W
R854	1-216-815-11	METAL CHIP 330 5%	1/10W
R856	1-216-815-11	METAL CHIP 330 5%	1/10W
R857	1-216-815-11	METAL CHIP 330 5%	1/10W
*****			

Ref. No.	Part No.	Description	Remark
ACCESSORIES			
*****			
	2-514-765-11	MANUAL, INSTRUCTION (ENGLISH,FRENCH)	
	2-514-765-21	MANUAL, INSTRUCTION (GERMAN,ITALIAN)	(AEP,UK,E)
	2-514-765-31	MANUAL, INSTRUCTION (SPANISH, TRADITIONAL CHINESE)	(AEP,UK,E)
	2-514-765-41	MANUAL, INSTRUCTION (DUTCH,PORTUGUESE)	(AEP,UK,E)
	2-514-765-51	MANUAL, INSTRUCTION (SWEDISH,POLISH)	(AEP,UK,E)
	2-514-765-61	MANUAL, INSTRUCTION (GREEK,RUSSIAN)	(AEP,UK,E)
*****			
PARTS FOR INSTALLATION AND CONNECTIONS			
*****			
101	3-367-410-11	SCREW (DIA. 5X15), TAPPING (MOUNTING SCREW)	
102	1-690-779-31	CORD (WITH CONNECTOR) (0.2m)	
103	3-249-791-01	COVER (POWER)	

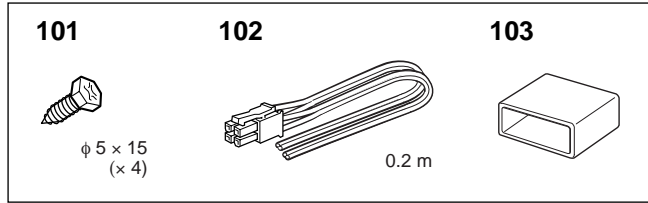

MEMO

